

A Holistic Workflow Modeling Method for Business Process Redesign

Heejeung Lee

Abstract—In a highly competitive environment, it becomes more important to shorten the whole business process while delivering or even enhancing the business value to the customers and suppliers. Although the workflow management systems receive much attention for its capacity to practically support the business process enactment, the effective workflow modeling method remain still challenging and the high degree of process complexity makes it more difficult to gain the short lead time. This paper presents a workflow structuring method in a holistic way that can reduce the process complexity using activity-needs and formal concept analysis, which eventually enhances the key performance such as quality, delivery, and cost in business process.

Keywords—Workflow management, reengineering, formal concept analysis.

I. INTRODUCTION

As the business environment are getting globally competitive, myriads of companies are facing a great demand for ways to develop the product or services in less time, at lower cost and with higher quality. These companies have also numerous business processes and the effective management of core business is a key success factor in competition and it delivers value to their customers and suppliers. Business process is a set of one or more linked procedures or activities which collectively realize a business objective or policy goal, normally within the context of an organizational structure that defines functional roles and relationships. Moreover, many companies have witnessed the emergence of an internet-based business environment where engineers, designers, and manufacturers are collaborating through the internet to participate in various business activities. This collaborative environment increases the degree of process complexity, which involves the barrier to enhance the key performance, especially the short lead time.

The purpose of this paper is firstly to present the workflow modeling method to show the how the control flows are defined, and secondly, to explore the opportunities to gain the short lead time by workflow restructuring method based on the activities-needs analysis.

II. WORKFLOW MODELING

The Workflow Management Coalition defines a workflow as “the automation of a business process, in whole or a part, during which documents, information, or tasks are passed from one agent to another for action, according to a set of procedural

Heejeung Lee is with the Department of Applied Systems, Hanyang University, South Korea (e-mail: stdream@hanyang.ac.kr).

rules [1].” Conventionally, workflow models are activity-based, and these activities are connected by two types of directed dependency – control flow and data flow [2], [3]. The control flow defines the execution sequence of various activities while activities are defined as the tasks that need to be carried out as part of a workflow. The data flow links output data of an activity to input data of one or more activities. This section focuses the control flow, and the data flow is secured by the activity-needs analysis in Section III.

A. Workflow Control Flow

Control flow is about the activities sequences, which can be specified in several ways: two activities can be directly connected, which means that the successor is ready for execution as soon as the predecessor is completed. In all other cases, connections among activities are represented by special-purpose routing rules, that is, splits and joins. Compositions of splits and joins may be used to represent iterations or other complex routing structures.

Definition 1. (Serial). After the predecessor is completed, the successor is to run. No split or join conditions occur during serial flow.

Definition 2. (And-Split). After the predecessor is completed, all successors are to run.

Definition 3. (Or-Split). Each successor is associated with a branch condition, and after the predecessor is completed, conditions are evaluated and only successors with a true condition are to run.

Definition 4. (And-Join). Only after all predecessors are completed, a successor is to run.

Definition 5. (Or-Join). The successor is to run every time whenever a predecessor is completed.

B. Workflow Matrix

Given a business process which consists of n activities, X_i ($i = 1, 2, \dots, n$), the workflow matrix \mathcal{W} is defined as a square matrix with n rows, n columns, and k markings, where n is the number of activities and k is the number of routings as depicted in (1) and Definitions 6-9. If there exists control flow from activity $_i$ to activity $_j$, then the value of elements m_{ji} is marked with one of the routing operators. Otherwise, the value is left empty.

$$\mathcal{W} = \begin{bmatrix} m_{11} & m_{12} & \dots & m_{1\ n-1} & m_{1n} \\ m_{21} & m_{22} & \dots & m_{2\ n-1} & m_{2n} \\ \vdots & \vdots & \dots & \vdots & \vdots \\ m_{n1} & m_{n2} & \dots & m_{n\ n-1} & m_{nn} \end{bmatrix} \quad (1)$$

More definitions are given below to specify the \mathcal{W} completely.

Definition 6. (Starting node). Given the \mathbb{W} , starting nodes are such activities as $s = \{j \mid \forall_i, m_{ji} \text{ is null}\}$.

Definition 7. (Ending node). Given the \mathbb{W} , ending nodes are such activities as $t = \{i \mid \forall_j, m_{ji} \text{ is null}\}$.

Definition 8. (Cyclic- \mathbb{W}). If there is neither starting node s nor ending node t in the \mathbb{W} , such \mathbb{W} is called cyclic- \mathbb{W} .

Definition 9. (Routing operators). There are five types of routing operators as shown in Fig. 1 such as:

- S : Two activities are said to be serial if one activity follows the other directly, and it is depicted in the \mathbb{W} by an S mark.
- A_s : And-Split denotes a point where a single thread of control is split into two or more parallel activities, and it is depicted in the \mathbb{W} by an A mark.
- A_j : AND-Join denotes a point where two or more parallel activities merge into a single common thread of control, and it is also depicted in the \mathbb{W} by an A mark.
- O_s : Or-Split denotes a point where a single thread of control makes a decision upon which branch(es) to take when it encounters with multiple activity branches, and it is depicted in the \mathbb{W} by an O mark.
- O_j : Or-Join denotes a point where one or more alternative activities remerge into a single common activity as the next step, and it is also depicted in the \mathbb{W} by an O mark.

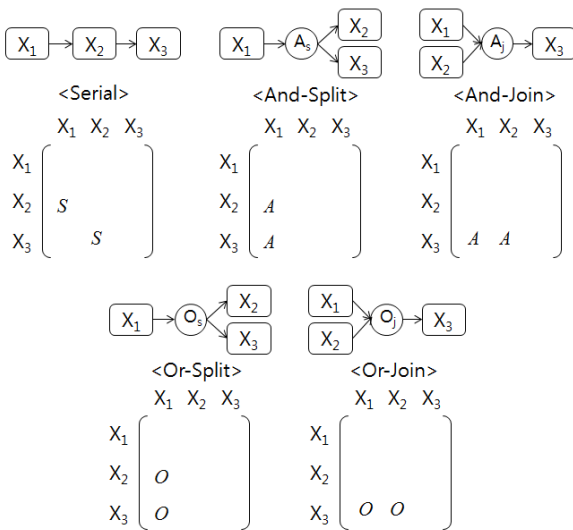

Fig. 1 Routing and Workflow Matrix Representation

Note that *Split* and *Join* are distinguished by their positions marked in the \mathbb{W} . The marks in the same column mean *Split* and the marks in the same row means *Join*.

Now we assume that there are 12 activities ($X_1 \sim X_{12}$) and some routings as depicted in Fig. 2. Then, the network representation of example workflow (note that routing S 's are omitted for the simplicity) can be converted from the workflow matrix as shown in Fig. 3.

$$\mathbb{W} = \begin{matrix} & X_1 & X_2 & X_3 & X_4 & X_5 & X_6 & X_7 & X_8 & X_9 & X_{10} & X_{11} & X_{12} \\ \begin{matrix} X_1 \\ X_2 \\ X_3 \\ X_4 \\ X_5 \\ X_6 \\ X_7 \\ X_8 \\ X_9 \\ X_{10} \\ X_{11} \\ X_{12} \end{matrix} & & & & & & & & & & S & S & \\ & & & & & S & & & & & & & \\ & & & A_s & & & & & & & & & \\ & S & & & & & & & & S & & & \\ & & & & & O_s & & & & & & & S \\ & & & A_j & & & & & & & A_j & & \\ & & & & & & & & & S & & & \\ S & & & & & S & & O_j & & & & & O_j \\ & S & & & & & & & & & & & \\ & & & O_s & & & & & & & & & \\ & & & & & & & & & & & & \end{matrix}$$

Fig. 2 Workflow Matrix

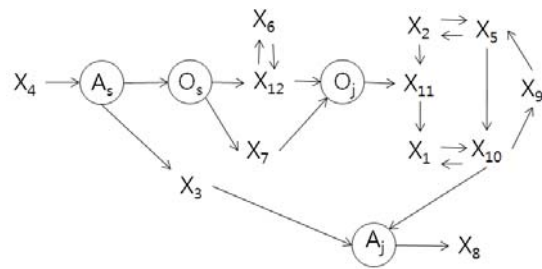

Fig. 3 Network Representation of Workflow

III. ACTIVITIES – NEEDS MATRIX

Given a set of activities A and a set of deliverables D , we can consider Activities-Needs Matrix (ANM), which provides a conceptual framework for structuring, analyzing and visualizing the relations between activities and deliverables in order to make them more understandable. We will also introduce two vectors (2)-(3), the row vector AM and the column vector NM in ANM as follows:

$$AM(X_i) = (d_{i1}, d_{i2}, \dots, d_{in}), d_{ij} \in [0, 1]. \quad (2)$$

$$NM(N_j) = (d_{1j}, d_{2j}, \dots, d_{nj}), d_{ij} \in [0, 1]. \quad (3)$$

For instance, we have the set of activities $A = \{X_1, X_2, X_3, X_4, X_5, X_6, X_7, X_8, X_9, X_{10}, X_{11}, X_{12}\}$ and the set of business needs $N = \{N_1, N_2, N_3, N_4, N_5, N_6, N_7, N_8, N_9, N_{10}\}$ as shown in Fig. 2. In Fig. 2, $AM(X_1) = (0.9, 0.1, 0.3, 0.2, 0.0, 0.0, 0.0, 0.1, 0.0, 0.7)$ represents that activity A_1 has the relationships with business needs N_1 to N_{10} with the degree of strength d_{1j} respectively, and the value of d_{1j} indicates how strongly X_1 influences N_j , where $j = 1, 2, \dots, 10$. If $d_{ij} = 0$, then there is no relationships between X_i and N_j . In a similar way, $NM(N_1) = (0.9, 0.8, 0.5, 0.0, 0.0, 0.0, 0.5, 0.1, 0.4, 0.0, 0.0, 0.0)$ represents that business needs N_1 are fulfilled by activities X_1 to X_{12} with the degree of strength d_{i1} , where $i = 1, 2, \dots, 12$.

ANM		Business Needs									
		N ₁	N ₂	N ₃	N ₄	N ₅	N ₆	N ₇	N ₈	N ₉	N ₁₀
Activities	X ₁	0.9	0.1	0.3	0.2	0.0	0.0	0.0	0.1	0.0	0.7
	X ₂	0.8	0.4	0.8	0.0	0.0	0.0	0.0	0.5	0.0	0.0
	X ₃	0.5	0.0	0.7	0.0	0.0	0.0	0.0	0.2	0.0	0.0
	X ₄	0.0	0.8	0.6	0.2	0.0	0.0	0.0	0.3	0.8	0.0
	X ₅	0.0	0.4	0.5	0.3	0.0	0.9	0.7	0.0	0.7	0.0
	X ₆	0.0	0.0	0.3	0.0	0.0	0.0	0.8	0.0	0.6	0.0
	X ₇	0.5	0.0	0.9	0.6	0.0	0.0	0.6	0.0	0.0	0.6
	X ₈	0.1	0.0	0.9	0.3	0.3	0.0	0.0	0.4	0.0	0.0
	X ₉	0.4	0.0	0.8	0.9	0.9	0.9	0.1	0.0	0.3	0.5
	X ₁₀	0.0	0.5	0.3	0.2	0.0	0.0	0.0	0.0	0.9	0.0
	X ₁₁	0.0	0.0	0.2	0.0	0.0	0.0	0.3	0.0	0.6	0.5
	X ₁₂	0.0	0.0	0.1	0.3	0.4	0.1	0.4	0.0	0.0	0.4

Fig. 4 Activity-Needs Matrix (ANM) example

For a mathematical theory of concepts and concept hierarchies, a well-structured approach is the computation of the concept lattice using Formal Concept Analysis (FCA) [4]. The idea behind this FCA is that the more properties are constrained, the fewer concepts satisfying the constraints. There are several algorithms for computing Galois Graph (Fig. 5), a partially ordered set, which can be constructed from the given Activity-Needs Matrix (Fig. 4) [5]. Borrowing FCA approach, we can define the *coupled activities* which are equivalence to the meaning of formal context in FCA.

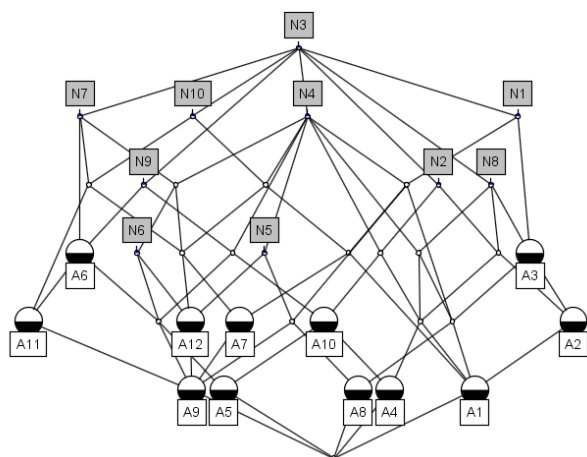

Fig. 5 Activity-Needs Graph (ANG) example

Definition 10. (*Coupled activities*). Let A is a finite set of activities, N is a finite set of business needs and R is a relation between A and N , i.e., $R \subseteq A \times N$, and given two sets $P \subseteq A$ and $Q \subseteq N$, we can consider the dual sets P' and Q' such as the sets defined by the business needs applying to all the activities belonging to P and the activities having relations with all the business needs belonging to Q , respectively, that is $P' = \{q \in N \mid \forall p \in P: (p, q) \in R\}$ and $Q' = \{p \in A \mid \forall q \in Q: (p, q) \in R\}$. Then a *coupled activities* is a pair (P, Q) , where $P' = Q$ and $Q' = P$.

The coupled activities have two parts, the extension and the intention from a philosophical point of view. The activities cover all business needs belonging to the coupled activities, while the business needs comprises all needs for all those coupled activities. We can find some coupled activities, for instance, from the Activity-Needs Graph as follows:

$$\begin{aligned} &(\{X_6, X_9, X_{11}\}, \{N_3, N_7, N_9\}), \text{ or} \\ &(\{X_9, X_{11}\}, \{N_3, N_7, N_9, N_{10}\}), \text{ or} \\ &(\{X_4, X_6, X_9, X_{11}\}, \{N_3, N_9\}) \end{aligned}$$

We observe that the main idea of coupled activities is that enlarging the set of activities will reduce the set of business needs involving with all these activities, whereas a smaller set of activities will meet a larger set of business needs. We also note that all of activities, X_6 , X_9 , and X_{11} have the relationships with the business needs, N_3 , N_7 , and N_9 , and vice-versa N_3 , N_7 , and N_9 apply to no other activities other than X_6 , X_9 , and X_{11} .

Considering this running example, we suppose that all non-null strength value d_{ij} between activities and business needs are assumed equal to 1. In the case of considering relationship strength d_{ij} in coupled activities, then the coupled activities above is, for instance, the pair:

$$\begin{aligned} &(\{X_6, X_9, X_{11}\}, \{(N_3, 0.2), (N_7, 0.1), (N_9, 0.3)\}), \text{ or} \\ &(\{X_9, X_{11}\}, \{(N_3, 0.2), (N_7, 0.1), (N_9, 0.3), (N_{10}, 0.5)\}), \text{ or} \\ &(\{X_4, X_6, X_9, X_{11}\}, \{(N_3, 0.1), (N_9, 0.3)\}). \end{aligned}$$

Definition 11. (*Strength intersection*). The intersection of related activities X_i ($i=1, 2, \dots, n$) for the business need N_k , with respective strength d_{ik} , the *strength intersection* is defined as: $d_{ok} = \min(d_{1k}, d_{2k}, \dots, d_{ik}, \dots, d_{nk})$

We can observe that the strength intersection can be computed on the basis of the fuzzy-like set intersection [6]. For instance, the coupled activities, $(\{X_6, X_9, X_{11}\}, \{(N_3, 0.2), (N_7, 0.1), (N_9, 0.3)\})$ is computed from the followings:

$$\begin{aligned} &(\{X_6, X_9, X_{11}\}, (N_3, 0.3)) \cap (\{X_6, X_9, X_{11}\}, (N_3, 0.8)) \cap \\ &(\{X_6, X_9, X_{11}\}, (N_3, 0.2)) \rightarrow (\{X_6, X_9, X_{11}\}, (N_3, 0.2)) \text{ and} \\ &(\{X_6, X_9, X_{11}\}, (N_7, 0.8)) \cap (\{X_6, X_9, X_{11}\}, (N_7, 0.1)) \cap \\ &(\{X_6, X_9, X_{11}\}, (N_7, 0.3)) \rightarrow (\{X_6, X_9, X_{11}\}, (N_7, 0.1)) \text{ and} \\ &(\{X_6, X_9, X_{11}\}, (N_9, 0.6)) \cap (\{X_6, X_9, X_{11}\}, (N_9, 0.3)) \cap \\ &(\{X_6, X_9, X_{11}\}, (N_9, 0.6)) \rightarrow (\{X_6, X_9, X_{11}\}, (N_9, 0.3)). \end{aligned}$$

IV. HOLISTIC WORKFLOW

In this section, we show how to effectively improve the business process with the help of holistic workflow model and activity-needs analysis, which is a technique for understanding, representing, and restructuring the current workflow. The first step to construct the holistic workflow is to identify the interaction between activities. We need to ask the agent who is responsible for each activity when we build up the control flows. The flows are marked in the W based on the routing operators. Consider our running example, for instance, we get an unordered or unstructured illustrative W in Fig. 6.

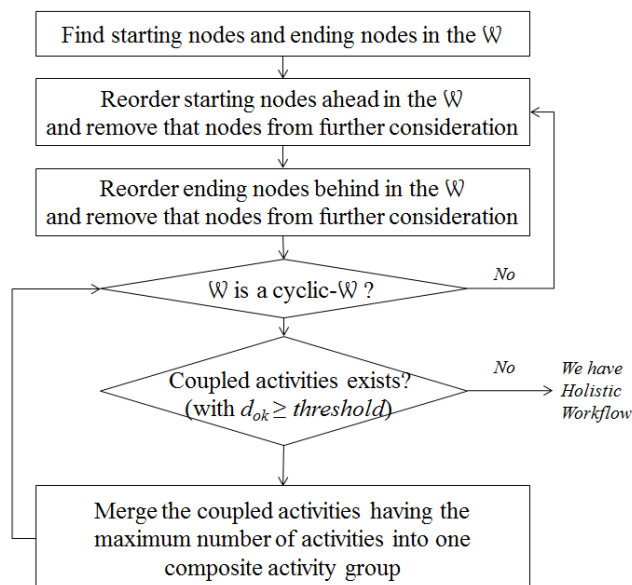

Fig. 6 Procedure to get the holistic workflow

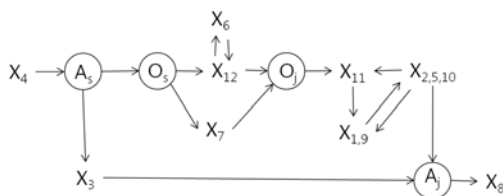

Fig. 7 Holistic Workflow

After some *reorder* iteration of procedure in Fig. 6, we can get the cyclic- \mathcal{W} consisting of eight activities: $X_1, X_2, X_5, X_6, X_9, X_{10}, X_{11}, X_{12}$. We also get the some coupled activities with strength intersection threshold, 0.2.

We can find the coupled activities which have the maximal activities, *i.e.*, three, with higher strength, 0.3, such as:

$$(\{X_2, X_5, X_{10}\}, \{(N_2, 0.4), (N_3, 0.3)\}).$$

Now we merge the above three activities, X_2, X_5, X_{10} into one composite activity group, for instance, $X_{2,5,10}$. Keeping the procedure to get the holistic workflow, we can find the coupled activities which have the maximal activities, *i.e.*, two, with higher strength, 0.2 such as:

$$(\{X_1, X_9\}, \{(N_1, 0.4), (N_3, 0.3), (N_4, 0.2), (N_{10}, 0.5)\}).$$

We also merge these X_1 and X_9 into the other composite activity group, for instance, $X_{1,9}$. Now we have the holistic workflow as shown in Fig. 7, which avoids the large scope iteration and reduces the process complexity as well.

The important feature of reengineering policy is to make good decision at earlier time where committed costs are relatively low [7]. Therefore, all factors on the downstream should be considered at earlier time, so that the potential problems can be handled as early as possible. The concurrent engineering is a well-known approach to handle this problem,

and has been studied and used in various fields. The iteration of activities, however, is needed to achieve the goal of concurrent engineering. We have overcome this iteration challenge by presenting the holistic workflow concept. Consider our running example, it is highly recommended that the coupled activities, X_2, X_5 and X_{10} , should be performed by some cohesive agents or team, both physically and organizationally, to facilitate communication. In a similar way, the other coupled activities X_1 and X_9 are also can be performed by another cohesive agents or team.

V. CONCLUSION

In restructuring business processes, some attempts to reduce the lead time may cause another problem that increases the business processes complexity, which makes it more difficult to manage them effectively or efficiently. In this paper, a novel workflow reengineering method for organizing business processes is developed to reduce the complexity and generate the holistic workflow in which we avoid the large scope iteration.

ACKNOWLEDGMENT

This research was supported by the National Research Foundation of Korea funded by the Korea government (NRF-2010-0022827)

REFERENCES

- [1] WfMC, *Terminology and Glossary*, WfMC-TC-1011, Workflow management coalition, 1996.
- [2] M. Kamath, and K. Ramamritham, "Correctness issues in workflow management," *Distributed Systems Engineering*, vol. 3, 1996, pp. 213-221.
- [3] F. Leymann, *Production workflow: concept and techniques*, New York: Prentice Hall, 2000.
- [4] R. Wille, Restructuring lattice theory: an approach based on hierarchies of concepts. In: Rival, I. (ed.) *Ordered Sets*. Dordrecht-Boston, Reidel, 1982
- [5] G. Snelting, "Reengineering of Configurations based on Mathematical Concept Analysis," *ACM Transactions on Software Engineering and Methodology*, vol. 5, no. 2, 1996, pp. 146-189
- [6] V. Krishnan, "Managing the simultaneous execution of coupled phases in concurrent product development." *IEEE Transactions on Engineering*, vol. 26, no. 3, 1994, pp. 521-536.
- [7] A. Formica, "Concept similarity in fuzzy formal concept analysis for semantic web," *International Journal of Uncertainty, Fuzziness and Knowledge-Based Systems*, vol. 18, no. 2, 2010. Pp. 153-167.